



Cyclone separators

Separators for liquids

Bernoulli

Cyclone separators

MATERIAL	DENSITY (kg /dm ³)
Aluminium	2,7
Ash	2,0
Brass	9,0
Bronze, Copper	8,9
Earth	1,2 – 2,0
Glass	3,0
Granite	2,5 – 3,0
Graphite	2,3
Iron	7,8
Lead	11,3
Limestone	2,8
Steel	7,8

Cyclone separators are designed to remove suspended solids from liquids. The separating efficiency depends on the flow velocity and the density of the particles. Liquid enters the upper chamber tangentially. The tangential inlet accelerates the flow before the liquid enters the separator. Centrifugal forces separate particles with higher density than the liquid, and they slowly fall down to the lower collection chamber.

The separating efficiency varies from 22–70 µm and depends on the density of the solids, higher density leads to finer separation. Separated solids are removed with an automatic purge system or with a manual purge valve. Time between purges and length of each purge is adjustable with the automatic purge system. Solid free liquid is drawn up through the vortex and exits the cyclone through its top outlet.

The cyclone separators are manufactured in connection sizes from 3/4" to 18", with a maximum capacity of 2.000 m³/h (8.800 gpm). The separators are manufactured in stainless steel AISI 304 / 316 or in epoxy coated carbon steel.

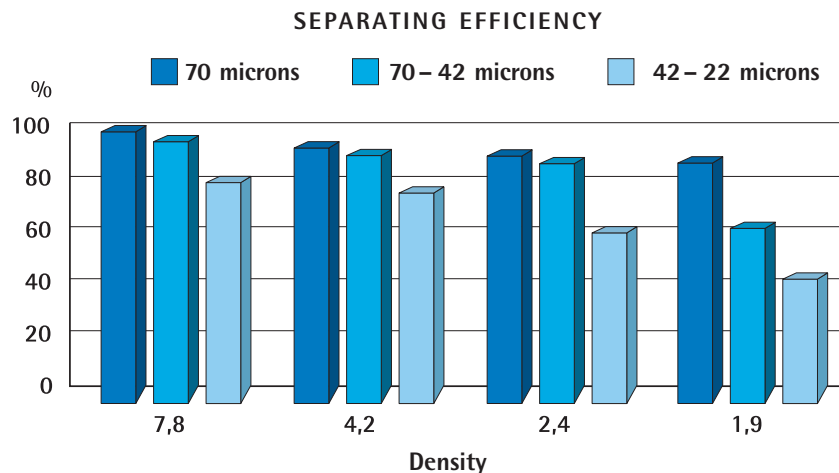
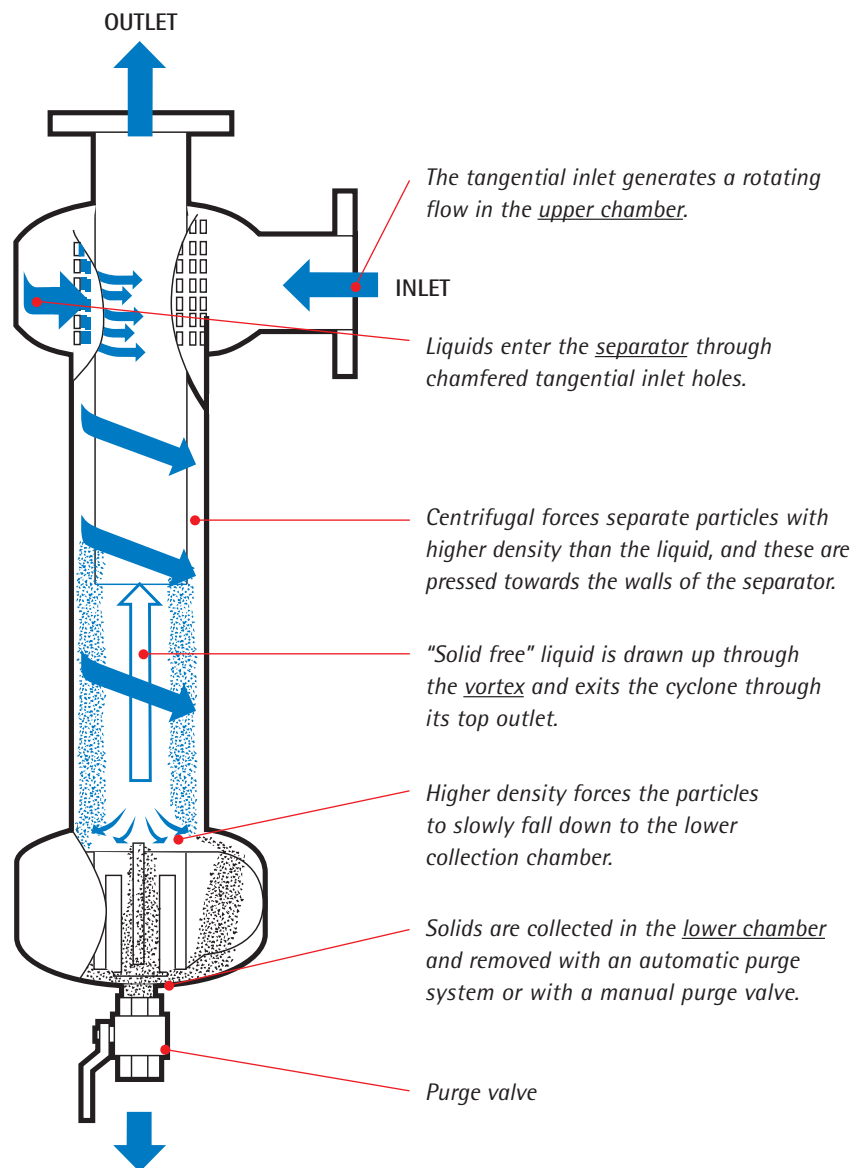

Efficient separation of particles



SELECTION CHART		
Model	Connection	Capacity (m ³ /h)
TMN 20	BSP 3/4"	1 – 4
TMN 25	BSP 1"	2 – 7
TMN 32	BSP 1 1/4"	7 – 10
TMN 40	BSP 1 1/2"	10 – 16
TMN 50	BSP 2"	16 – 24
TMN 65	BSP 2 1/2"	24 – 35
TMN 80	BSP 3"	35 – 65
TMF 100	DN 100	65 – 90
TMF 125	DN 125	90 – 110
TMF 150	DN 150	110 – 200
TMF 200	DN 200	200 – 380
TMF 250	DN 250	375 – 700
TMF 300	DN 300	560 – 900
TMF 350	DN 350	650 – 1200
TMF 400	DN 400	860 – 1600
TMF 450	DN 450	1100 – 2000

PRESSURE DROP CHART

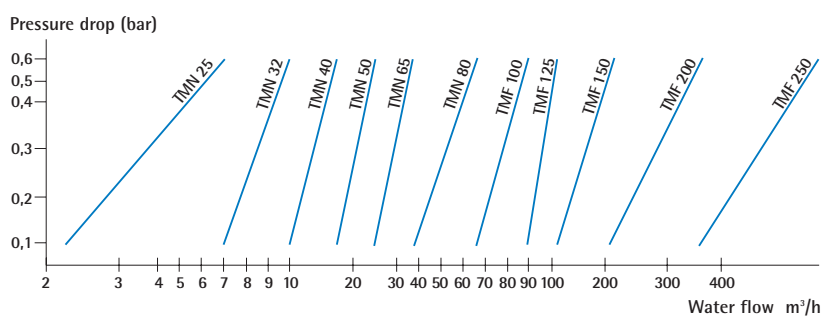

ADVANTAGES

- Continuous operation
- Easy installation
- Very small liquid losses during purging
- No interruptions during purging
- No need for by-pass installation
- No need for regular maintenance
- No moving parts
- ISO 9001 standard

APPLICATION AREAS

Intake water

Well water, surface water, lake water, river water, seawater and injection water.

Process water

For protection of spray nozzles, sand filter, membrane filter, bag filter, Reversed Osmosis (RO) and ultra filtration.

Cooling tower water

Cyclone separators are used for removal of solids in circulating cooling tower water.

Cooling water

Steelwork, power stations, chemical industries and wash water.

Wastewater

Cyclone separators are used for removal of sand in sewage water systems and overflow basins.

Refineries and oil industries

Degreasing plants, cooling water and fire protection system.

Vertical separators with flanged or threaded connections

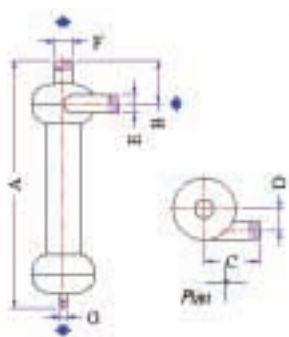

TMN Capacity:
1 – 65 m³/h

Connection:
BSP

Material:
Stainless steel (AISI 304 / 316), Carbon steel (externally epoxy coated)

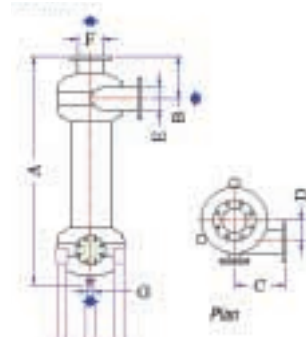

TMF Capacity:
65 – 2000 m³/h

Connection:
DIN flanges

Material:
Stainless steel (AISI 304 / 316), Carbon steel (externally epoxy coated)

TMN	A	B	C	D	E / F	G
20	600	110	130	67	BSP 3/4"	BSP 3/4"
25	690	110	130	63	BSP 1"	BSP 1"
32	760	125	165	89	BSP 1 1/4"	BSP 1"
40	760	130	170	86	BSP 1 1/2"	BSP 1"
50	860	135	175	80	BSP 2"	BSP 1"
65	880	155	195	72	BSP 2 1/2"	BSP 1"
80	1040	167	215	80	BSP 3"	BSP 1"

TMF	A	B	C	D	E / F	G
100	1110	167	260	93	DN 100	BSP 1"
125	1310	225	270	80	DN 125	BSP 1 1/4"
150	1700	255	345	143	DN 150	BSP 1 1/2"
200	2300	355	435	165	DN 200	BSP 1 1/2"
250	2850	470	545	188	DN 250	BSP 2"
300	4380	660	610	240	DN 300	BSP 2"

Sizes up to 20" are available on request.

25° Configuration

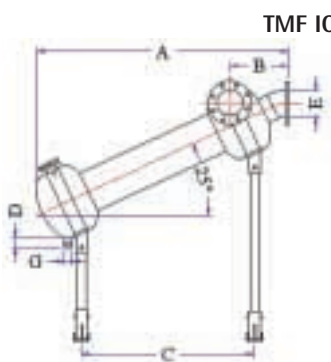

TMF IO Capacity:
65 – 2000 m³/h

Connection:
DIN flanges

Material:
Stainless steel (AISI 304 / 316), Carbon steel (externally epoxy coated)

Standard:
The separator has 25° configuration and an inspection opening in the bottom chamber.

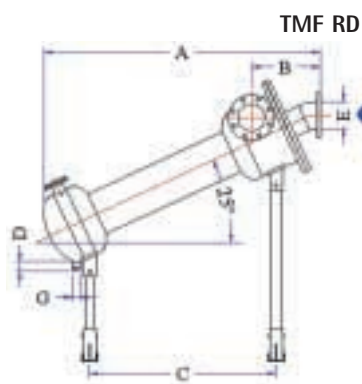

TMF RD Capacity:
65 – 2000 m³/h

Connection:
DIN flanges

Material:
Stainless steel (AISI 304 / 316), Carbon steel (externally epoxy coated)

Standard:
The separator has 25° configuration and an inspection opening in the bottom chamber. The upper chamber has a removable domed end cover for inspection.

TMF IO	A	B	C	D	E	G
100	1180	350	750	100	DN 100	BSP 1 1/4"
125	1240	350	790	100	DN 125	BSP 1 1/4"
150	1600	384	1010	100	DN 150	BSP 1 1/2"
200	2142	586	1320	100	DN 200	BSP 1 1/2"
250	2753	715	1790	100	DN 250	BSP 2"
300	4180	930	2850	100	DN 300	BSP 2"
350	4148	942	2856	150	DN 350	BSP 3"
400	4148	942	2586	150	DN 400	BSP 3"
450	4287	1029	2995	150	DN 450	BSP 3"

TMF RD	A	B	C	D	E	G
100	1180	350	750	100	DN 100	BSP 1 1/4"
125	1240	350	790	100	DN 125	BSP 1 1/4"
150	1600	384	1010	100	DN 150	BSP 1 1/2"
200	2142	586	1320	100	DN 200	BSP 1 1/2"
250	2753	715	1790	100	DN 250	BSP 2"
300	4180	930	2850	100	DN 300	BSP 2"
350	4148	942	2856	150	DN 350	BSP 3"
400	4148	942	2586	150	DN 400	BSP 3"
450	4287	1029	2995	150	DN 450	BSP 3"



AHTT Pty Ltd. Unit 4-185 Briens Road. Northmead. NSW. 2152. Australia
Tel: 02-9890-7122 • Fax: 02-9890-7133
E-mail: ahtt@bigpond.net.au • www.heattransfer.com.au